

Model Shown:

PE554S, PE552, PE554W

Pumps



Features

INDUSTRY LEADING HEAVY-DUTY PUMP FOR MULTIPLE APPLICATIONS

- 1-1/8 hp, 12,000 rpm, 110/115VAC, 50/60 Hz universal motor. Draws 25 amps at full load, starts at reduced voltage.
- True unloading valve achieves greater pump efficiency, allowing higher flow at maximum pressure.
- Reservoirs available in sizes up to 10 gallons, refer to pump accessories page.
- Lightweight and portable. Best performance-to-weight ratio of all Power Team pumps.
- 10 foot remote motor control (except PE552S which has a 25 foot remote motor and valve control).
- “Assemble to Order” System allows you to choose from a wide range of pre-engineered, off-the-shelf components to build a customized pump to fit specific requirements. Refer to the “Assemble to Order” (ATO) Pump Pages.
- CSA rated for intermittent duty.



Torque Wrench Pumps



For Torque Wrench Pump Configurations, refer to the Tools Section.

Performance Specifications

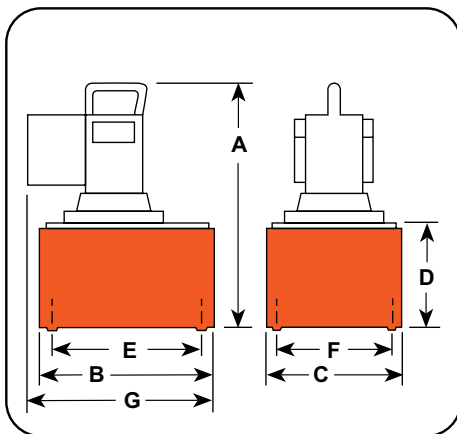
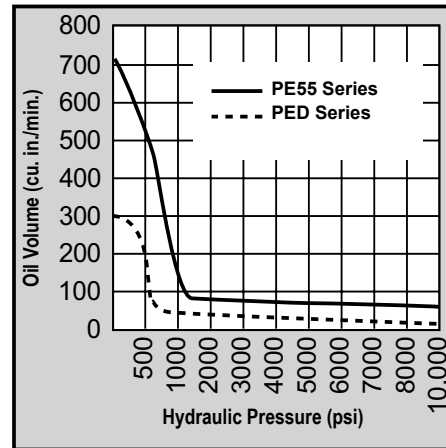

Technical Dimensions

Order No.	A	B	C	D	E	F	G	Max. Pressure Output (psi)	rpm	dBA at Idle and 10,000 (psi)	115VAC* Amp Draw at 10,000 (psi)	Oil Del. (cu. in./min. @)				Prod. Wt. with Oil (lbs.)
												0 (psi)	700 (psi)	5,000 (psi)	10,000 (psi)	
PE55 Series	18.25 (in.)	11.50 (in.)	9.50 (in.)	7.00 (in.)	10.00 (in.)	8.00 (in.)	14.00 (in.)	10,000	12,000	90/89*	25	704 (psi)	440 (psi)	74 (psi)	56 (psi)	65.00

* Amp draw at 10,000 psi, 230VAC 50/60 Hz is 15 Amps.

Ordering Information

For Use With Cylinder Type	Description	Order No. ***	Valve Type	Valve No.	Valve Function	Control Switch ††	Motor	Reservoir Usable Oil Cap. (cu. in.)
Single-Acting	Base model 1-1/8 hp pump with 2.5 gallon reservoir, & remote motor control	PE550	-	-	-	Remote Motor	1 1/8 hp*, 110/115VAC 50/60 Hz, Single-Phase	525
Single-Acting	Base model 1-1/8 hp pump with 5 gallon reservoir, remote motor control.	PE550-RP50	-	-	-	Remote Motor	1 1/8 hp*, 110/115VAC 50/60 Hz, Single-Phase	1150
Single-Acting	Base model 1-1/8 hp pump with 2.5 gallon reservoir, remote motor control, & 3-way valve.	PE552	3-Way	9582	Advance Return **	Remote Motor	1 1/8 hp*, 110/115 VAC 50/60 Hz, Single-Phase	525
Single-Acting	1-1/8 hp pump with 2.5 gallon reservoir, remote motor control, & solenoid-operated remote valve.	PE552S	3-Way	9579	Advance Hold Return	Remote Motor & Valve	1 1/8 hp*, 110/115VAC 50/60 Hz, Single-Phase	525
Single-Acting	1-1/8 hp pump with 5 gallon reservoir, remote motor control, & solenoid-operated remote valve.	PE552S-RP50	3-Way	9579	Advance Hold Return	Remote Motor & Valve	1 1/8 hp*, 110/115VAC 50/60 Hz, Single-Phase	1150
Single-Acting	1-1/8 hp pump with 2.5 gallon reservoir, remote motor control, & "Auto Dump" valve.	PE552A∞	Auto/Dump	9610	Advance Return	Remote Motor	1 1/8 hp*, 110/115VAC 50/60 Hz, Single-Phase	525
Single-Acting	1-1/8 hp pump with 2.5 gallon reservoir. Valve has "Posi-Check" feature	PE553	3-Way†	9520	Advance Hold Return	Remote Motor	1 1/8 hp*, 110/115VAC 50/60 Hz, Single-Phase	525
Single-Acting	1-1/8 hp pump with 5 gallon reservoir. Valve has "Posi-Check" feature	PE553-RP50	3-Way†	9520	Advance Hold Return	Remote Motor	1 1/8 hp*, 110/115VAC 50/60 Hz, Single-Phase	1150
Double-Acting	Base model 1-1/8 hp pump with 2.5 gallon reservoir, and 4-way valve for double-acting systems	PE554	4-Way†	9506	Advance Hold Return	Remote Motor	1 1/8 hp*, 110/115VAC 50/60 Hz, Single-Phase	525
Double-Acting	Base model 1-1/8 hp pump with 5 gallon reservoir, and 4-way valve for double-acting systems	PE554-RP50	4-Way†	9506	Advance Hold Return	Remote Motor	1 1/8 hp*, 110/115VAC 50/60 Hz, Single-Phase	1150
Double-Acting	Pump equipped with 3/4-way solenoid valve, and 5 gallon reservoir	PE554S-RP50	3/4-Way	9592	Advance Hold Return	Remote Motor & Valve	1 1/8 hp*, 110/115VAC 50/60 Hz, Single-Phase	1150
Double-Acting	Weather-resistant model 1-1/8 hp pump with 2.5 gallon reservoir, and 4-way valve for double-acting systems.	PE554W	4-Way†	9506	Advance Hold Return	Remote Motor	1 1/8 hp*, 110/115VAC 50/60 Hz, Single-Phase	525
Double-Acting	Weather-resistant model 1-1/8 hp pump with 5 gallon reservoir, and 4-way valve for double-acting systems.	PE554W-RP50	4-Way†	9506	Advance Hold Return	Remote Motor	1 1/8 hp*, 110/115VAC 50/60 Hz, Single-Phase	525
Double-Acting	1-1/8 hp pump with 2.5 gallon reservoir, and 9500 tandem center valve for double-acting systems.	PE554T	4-Way	9500	Advance Hold Return	Remote Motor	1 1/8 hp*, 110/115VAC 50/60 Hz, Single-Phase	525
Double-Acting	For use with single-acting Spring Seat, Stressing Jack or double-acting cylinder.	PE554P	4-Way	9500	Advance Hold Return	Remote Motor	1 1/8 hp*, 110/115VAC 50/60 Hz, Single-Phase	525
Double-Acting	"For use with single-acting or double-acting Power Seat, Stressing Jacks ONLY."	PE554PT	4-Way	9628	Advance Hold Return	Remote Motor	1 1/8 hp*, 110/115VAC 50/60 Hz, Single-Phase	525
Double-Acting	Pump suitable to run multiple spring return tools.	PE554C	4-Way	"9511 †††"	Advance Hold Return	Remote Motor	1 1/8 hp*, 110/115VAC 50/60 Hz, Single-Phase	525
Double-Acting	Pump equipped with 3/4-way solenoid valve.	PE554S	3/4-Way	9592	Advance Hold Return **	Remote Motor & Valve	1 1/8 hp*, 110/115VAC 50/60 Hz, Single-Phase	525

* Pumps available with 230VAC, 60/50 Hz motors. Specify voltage when ordering. See "Assemble to Order" pump options

** Holds with motor shut-off.

† Valves have Posi-Check® feature.

†† All remotes are 10 ft. long except for PE552S which is 25 ft. long.

††† Valving allows alternate and independent operation of two different spring return tools. Valve holds pressure only while valve is in "A" or "B" port position with pump motor shut-off.

∞ Not to be used for lifting.

Model Shown:

PE604T, PE604PT

Pumps



▶ The PE60 used for pre-stressing application



▶ Features

COMPACT, LIGHTWEIGHT PUMP. EXCELLENT CHOICE FOR RUGGED APPLICATIONS AND LOW VOLTAGE STARTING.

- Pump offers long, trouble-free life in the most demanding work environments.
- For operating single or double-acting cylinders, or stressing jacks.
- Powered by 1-1/8 hp, 115VAC, 50/60 Hz single-phase motor. Starts under load, even at reduced voltages at construction sites.
- Optional fan-driven external oil cooler includes rollover guard.
- Insulated carrying handle.
- Integral 4" dia. fluid-filled pressure gauge with steel bezel complies with ASME B40.1 Grade A.
- Sealed 0.754 gallon (usable) reservoir. Reservoir drain port is standard.
- Oil level sight gauge for accurate oil level monitoring.
- External spin-on filter removes contaminants from circulating oil to maximize pump, valve and cylinder/ tool life.
- CSA rated for intermittent duty.

▶ Performance Specifications

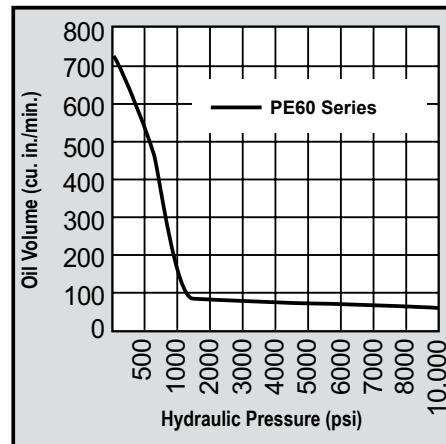



Optional: Oil Cooler Kit

For Use With:	Kit Order No.	Voltage	Wt. (lbs.)
PE604T	252511	115VAC	5.00
or PE604PT	252512	220VAC	5.00



Hydraulic Fluids



For dependable performance of all your hydraulic pumps and cylinders. Power Team specialty blended oils contains foam suppressant additives and has a high viscosity index. Refer to the Accessories section for complete details



Learn More - About Hydraulic Safety Insight



Looking for great safety suggestions? Visit our Resource Section to get a better understanding of hydraulic and mechanical safety insights on what to look for when working around hydraulics

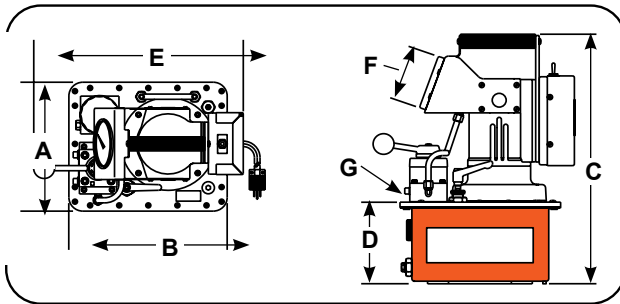

Technical Dimensions

Order No.	A (in.)	B (in.)	C (in.)	D (in.)	E (in.)	F (in.)	G (in.)	Max. Pressure Output (psi)	rpm	dBA at Idle and 10,000 (psi)	115VAC Amp Draw at 10,000 (psi)	Oil Del. (cu. in./min. @)				Prod. Wt. with Oil (lbs.)
												0 (psi)	700 (psi)	5,000 (psi)	10,000 (psi)	
PE604T	9.31	11.50	18.25	6.00	15.00	4.00	3/8 NPTF	10,000	10,000	80/85	25	704	440	74	56	50.00
PE604PT	9.31	11.50	18.25	6.00	15.00	4.00	3/8 NPTF	10,000	12,000	80/85	25	704	440	74	56	51.00

NOTE: Unloading pressure is 1,000 psi.

Ordering Information

For Use With Cylinder Type	Description	Order No.	Valve Type	Valve No.	Valve Function	Control Switch	Motor	Reservoir Usable Oil Cap. (cu. in.)
Single-Acting, Spring Seat, Stressing Jack or Double-Acting	1-1/8 hp pump with 0.75 gallon reservoir & valve for double-acting systems.	PE604T	4-Way/3-Position	9500	Advance Hold Return	On/Off Pulse	1-1/8 hp, 115VAC 60/50 Hz, Single-Phase	157
Single-Acting or Double-Acting Power Seat, Stressing Jacks Only	1-1/8 hp pump with 0.75 gallon reservoir & a special valve for post-tensioning application only.	PE604PT	4-Way/3-Position	9628 Model C	Advance Hold Sequenced Return	On/Off Pulse	1-1/8 hp, 115VAC 60/50 Hz, Single-Phase	157

NOTE: Contact Factory for PE60 pump models with other control and valve options.

NOTE: For 220/230VAC, 50/60 Hz, single-phase models, add -220 suffix.